

# BACKWARD CURVED

## SISW CENTRIFUGAL FANS

### BSZ Series - Direct Driven



SAGAR AIR PVT. LTD.

Product Coding :

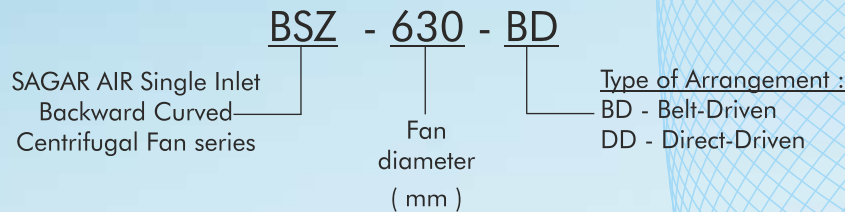

MS Powder Coated / GI Fan Scroll

Direct Driven with Branded IP55 Squirrel Caged Flanged Induction Motor

BC Dynamically Balanced Impellar



High Quality FRP Inlet Cone

Branded Pre-lubricated Grooved Ball Bearings and Pillow Block units

High quality C45 Grade Steel Shafts

Rigid Mild Steel - Powder coated Fan Stool Construction

#### Optional Accessories :

- Casing Drain
- Outlet and Inlet Flanges
- Guards
- Silencers
- Inspection Doors

**Rigid Construction**

**High Operational Performance**

**Sophisticated Design**

**Low and Inexpensive Maintenance**

**Superior Dynamic Balancing**

**Low Operating Noise and Vibration**

#### Applications :

- Ventilation - Exhaust / Supply
- Cement Industries
- Kitchens, Restaurants and Hotels
- Paint Industries
- Chemical Formulations and many more....

# Technical Specs : Direct -Driven

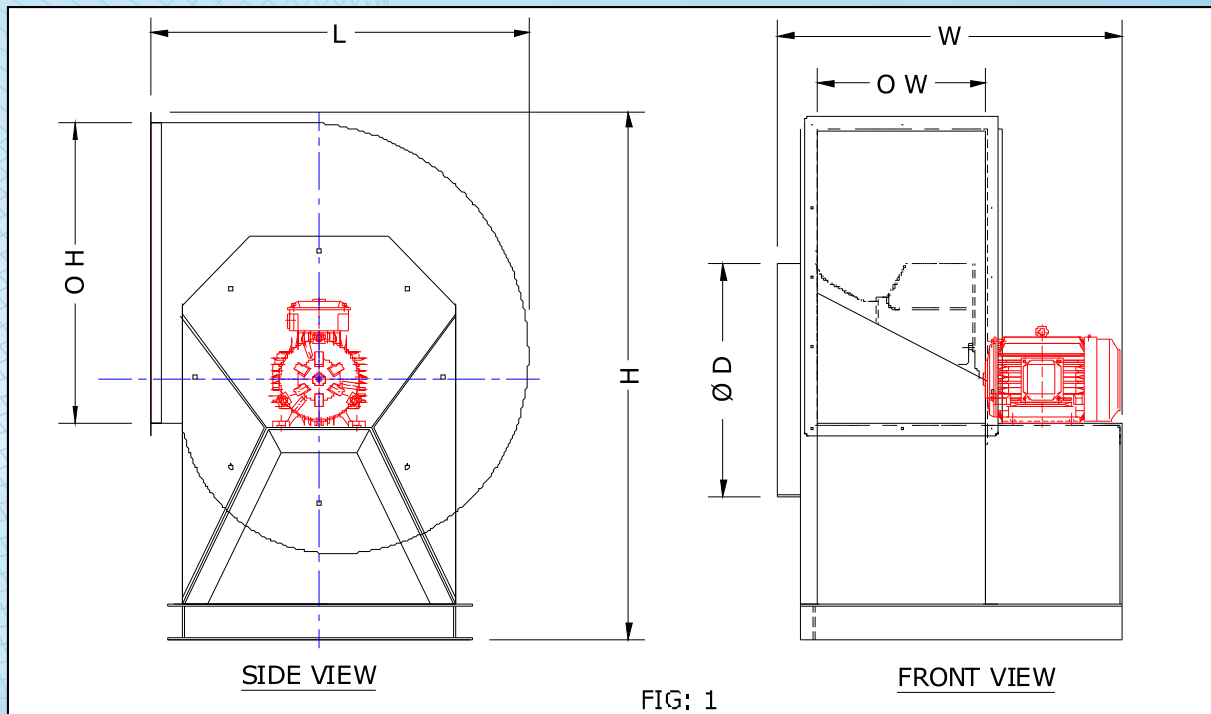

FIG: 1

Fan Model	CFM AT TOTAL STATIC PRESSURE				MOTOR		Overall Dimensions mm						OV (m/s)	Fan Opening OWxOH	Air Inlet D	STATIC EFF %
	50	60	75	90	RPM	KW	FRONT DIS			TOP DIS						
							L	W	H	L	W	H				
BSZ - 500	4600	4000	3400	1762	1440	2.2	800	770	1150	800	770	1050	9.2	500 x 500	500	65.3
BSZ - 560	6925	6545	5789	5000	1440	3.7	950	900	1250	1200	810	1150	9.1	560 x 560	560	67.1
BSZ - 630	10475	9914	9352	8829	1440	5.5	1150	1100	1150	1150	1100	1200	9.5	630 x 630	630	72.9
BSZ - 710	9431	8500	6598	4331	1000	5.5	1165	1180	1400	1300	1250	1200	9.9	710 x 710	710	67.2
BSZ - 800	14555	13755	12156	10000	1000	5.5	1350	1300	1400	1350	1300	1400	9.2	800 x 800	800	72.8

- Casing : Rigid Galvanized Iron fan casing.
- Fully Rotatable Fan System in 3 orientations for various requirements
- Motor System : Equipped with Highly efficient and powerful Direct drive motor of high quality which provides reliable air delivery at nominal maintenance costs. The motor is Squirrel caged, Direct Drive induction motor with Class F insulation.



**SAGAR AIR PVT. LTD.**

**Address:** Plot No.96-97, IDA Uppal,  
Hyderabad - 500039, Telangana, INDIA.  
**Tel:** 040-27201792 **Fax:** +91-40-27204837  
**Mail:** [sagarair@gmail.com](mailto:sagarair@gmail.com), [info@sagarair.com](mailto:info@sagarair.com)  
**Web:** [www.sagarair.com](http://www.sagarair.com)